

IEC
SOLID OUTPUT
SHAFT OPTION
DETAIL

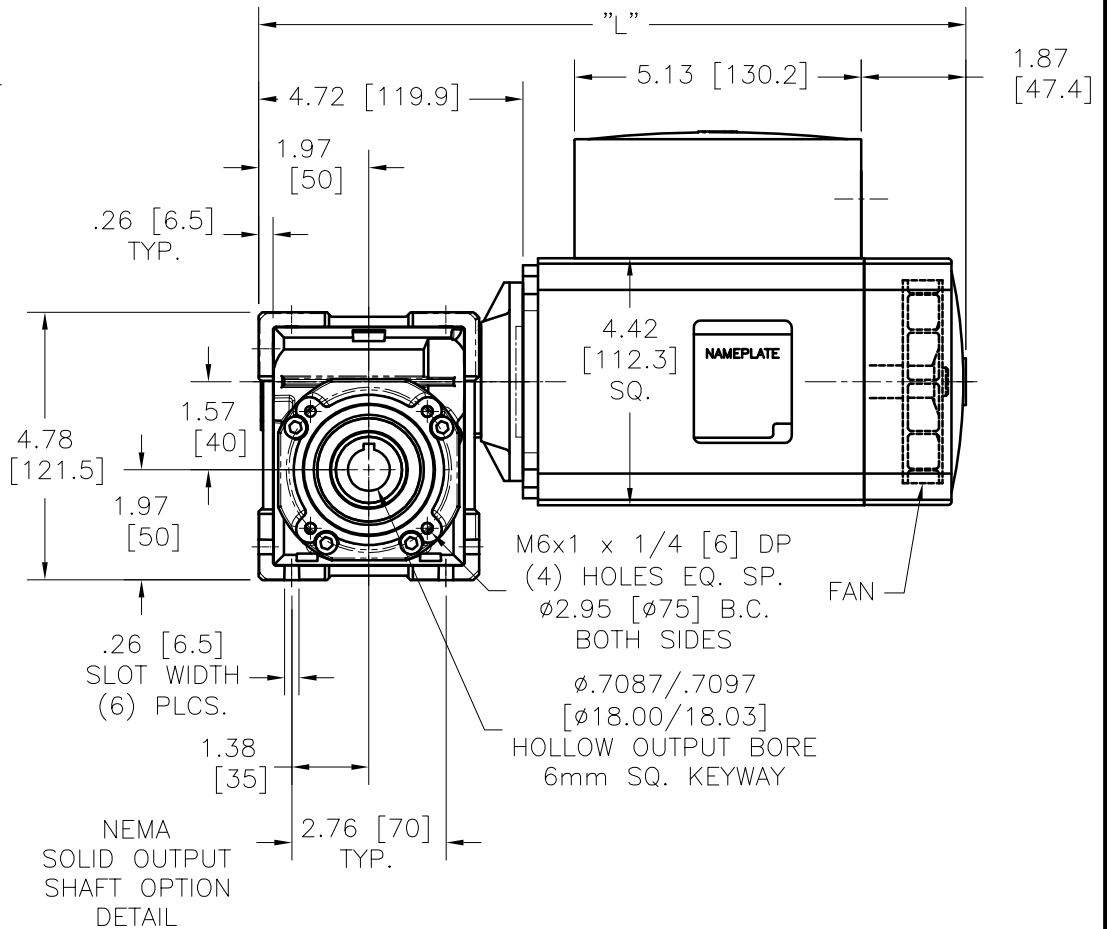

NEMA
SOLID OUTPUT
SHAFT OPTION
DETAIL

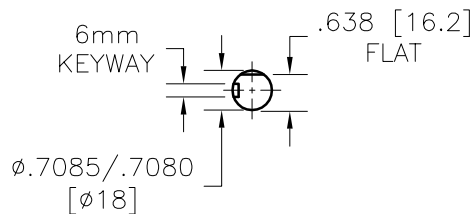
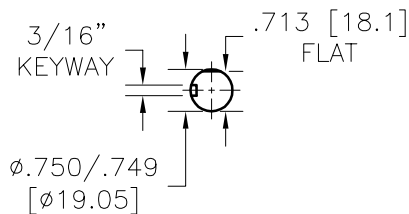

NOTES:

1. ALL DIMENSIONS ARE NOMINAL.
2. [mm] = MILLIMETERS.

MODEL	"L"
AC10060FC-RA40__T	12.64 [321]
AC10080FC-RA40__T	13.43 [341]

AC100__FC-RA40__T
CATALOG STANDARD



REV: 2
DATE: 6-27-17