BLDC SPEED CONTROL INSTRUCTION MANUAL

Programmable digital "closed loop" motor speed control system for brushless motors



groschopp.com

420 15th St NE, Sioux Center, IA 51250

Phone 712.722.4135

Toll-Free 800.829.4135

Email sales@groschopp.com

FAX 712.722.1445

Table of Contents

Introduction	2
General Features	2
Installation and Mechanical Dimensions	3
Exploded Panel View.....	3
Cut-out and Mounting Dimensions	3
P1 Terminal Block Hook-Up Diagrams.....	4
P1 Terminal Block Descriptions.....	4
Hook-up Procedure for Motors With Timing Diagrams	5
Hook-up Procedure for Motors Without Timing Diagrams	5
Adjustments	6
Current Limit	6
Internal Fault LED	6
Basic Operating Instructions	6
Control Algorithm Discussion and P-I-D Tuning	6
Rate and Time Mode Explained	7
Visual Reference	7
How to Change an Item's Value (The Short Story).....	7
Operating the User Interface (The Long Story)	7
Detailed Configuration Instructions	8
Default Configuration.....	8
Resetting the Unit to Factory Defaults.....	9
JP1 (Program Enable Jumper)	9
Setting and Reading "SoftSwitches"	9
Setting and Reading "Alarm" Conditions	10
"Alarm" Output Routing	11
Alarm "Logic"	11
Software Parameters (Items).....	13
Item (Parameter) Descriptions.....	16
Application Example	25
Conveyor Oven Control with Alarm Output	25
Troubleshooting	27
Specifications	28
Electrical.....	28
Mechanical	28
Environmental.....	28
Dimension Chart.....	28

Introduction

The Groschopp DB2110D-2 BLDC control is a compact, microprocessor-based unit capable of being either field or factory configured for a number of industry's motion control needs. The control is designed around a velocity form PID algorithm. The BLDC drive is easily configured to operate as a digital speed controller and time-based process controller. The BLDC drive is ideal for volume OEM Adjustable Speed Control applications. Contact Groschopp's Sales Department for details.

The BLDC drive's durable 1/8 DIN NEMA 4X aluminum housing can be easily mounted in a panel or control cabinet. The new pluggable terminal block allows the user to quickly install or replace units without the hassle of physically removing and reattaching wires.

General Features

- Microprocessor-based design allows for incredible flexibility to suit process control needs
- ModularBus expansion makes it possible for the BLDC control to accommodate a wide variety of I/O
- Digital closed-loop algorithm ensures accuracy of $\pm 1/2$ RPM of set speed or equivalent
- Non-volatile memory stores settings without batteries, even when power has been removed
- Factory or field programmable via front-panel keypad
- Many adjustable settings include min, max, accel, decel, display options, and more
- Internal program-enable jumper selectively prevents tampering with unit's configuration
- Power supply input accepts 12 or 24-48VDC (Jumper selectable).
- Transient voltage protection prolongs unit's life in harsh industrial environments
- Self-contained power supply for external speed pickups, limited to 5V @ 50mA
- One separate programmable alarm output with Form C contacts
- Flexible user inputs support Inhibit, Emergency-Stop, and Jog functionality
- Large 4 digit, 1/2" LED display, with user-settable decimal point (colon displayed in Time mode)
- Durable NEMA 4X rated aluminum housing with Polycarbonate membrane and gasket (which are included) meet NEMA 4X standards when used with NEMA 4X enclosures
- Wide operating ambient temperature range of -10°C to 40°C (14°F to 104°F)
- Multiple operating modes are available in closed-loop operation, including:
 - Rate Mode – Controls in rate unit such as RPM, Gallons per Minute, etc.
 - Time Mode – Controls in time unit such as HH:MM, MM:SS, SS:TT, or other unit
- 60° or 120° Hall Sensor spacing is jumper selectable
- Forward or Reverse rotation of motor is jumper selectable

Installation and Mechanical Dimensions

Exploded Panel View

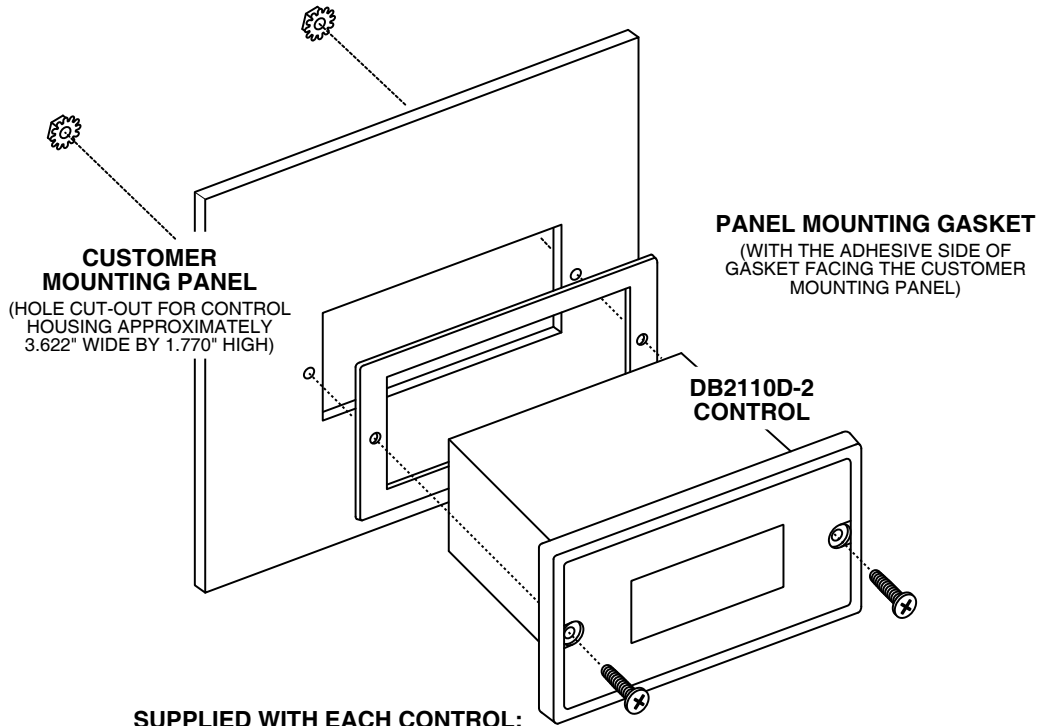

SUPPLIED WITH EACH CONTROL:

- 1) GASKET
- 2) (2) 6-32 X 3/4 PANHEAD BLACK OXIDE STAINLESS SCREWS
- 3) (2) #6 NUT WITH LOCKWASHER

Cut-out and Mounting Dimensions

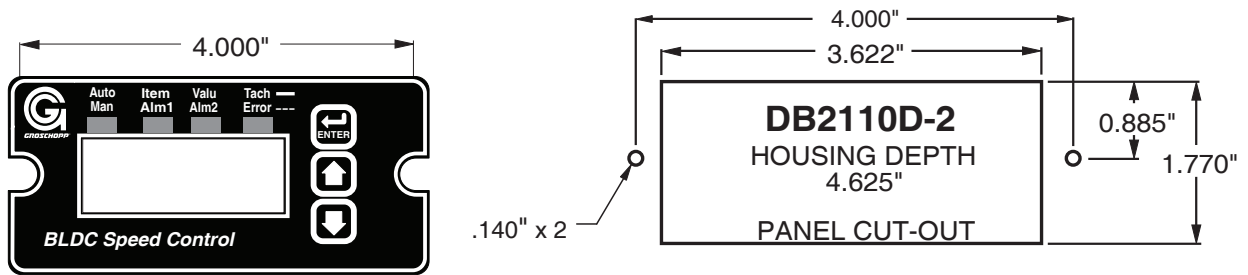

DB2110D-2 Dimensions

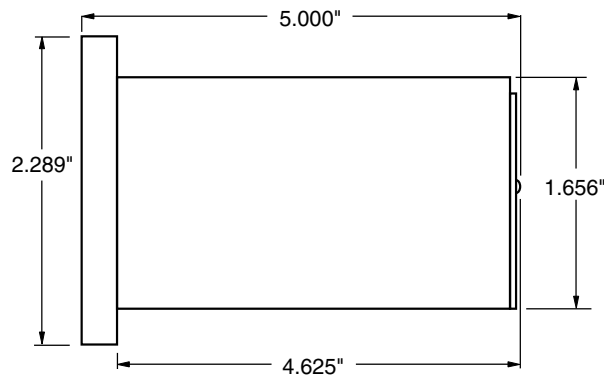

Electrical Installation & Diagrams

P1 Terminal Block Hook-Up Diagrams

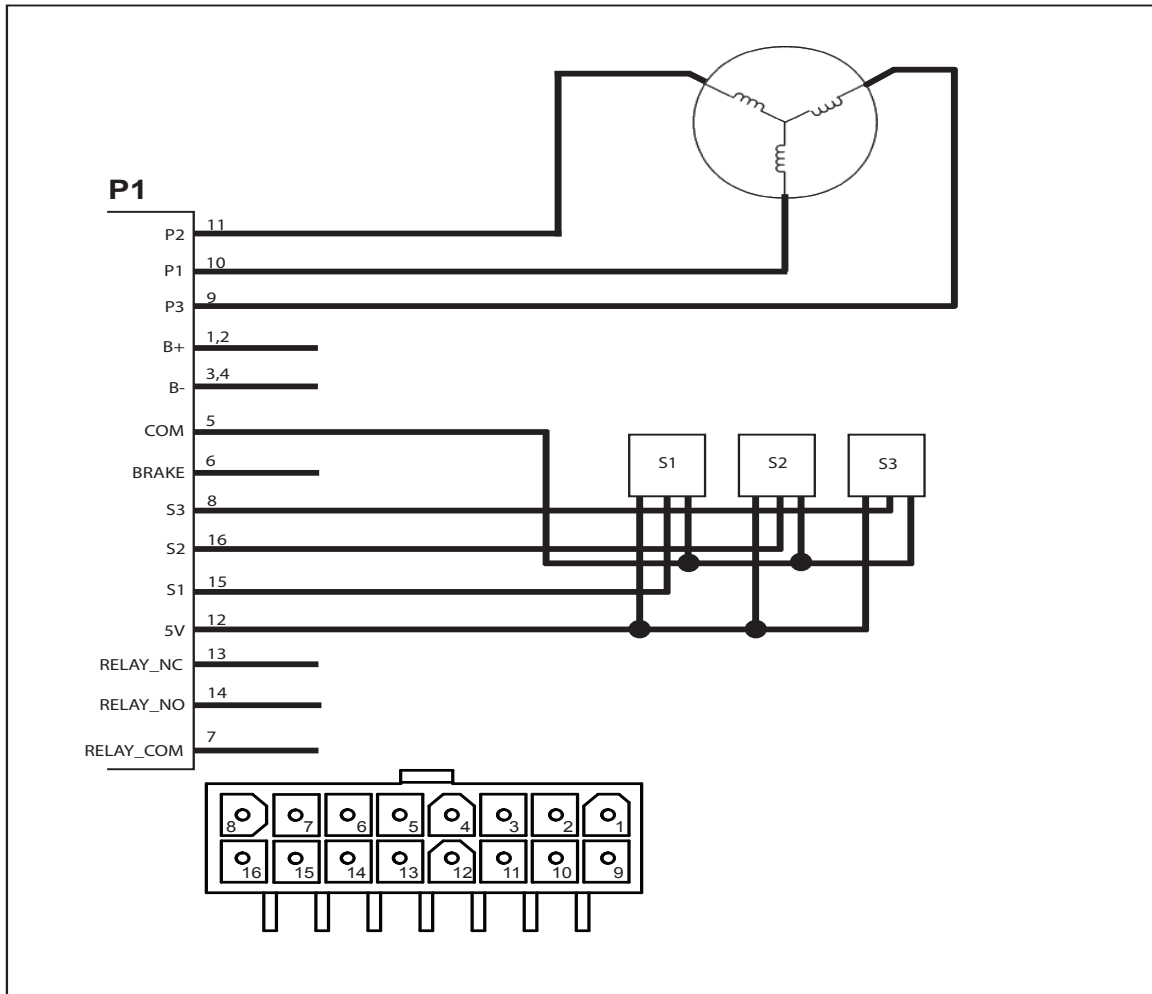

P1 Terminal Block Descriptions

- P1-1&2 (B+) - The Positive input from an external DC power supply.
- P1-3&4 (B-) - The Negative input from an external DC power supply.
- P1-5 (COM) - This is the common terminal. The speed sensor common lead as well as any other source needing to reference the control common will be connected to this terminal.
- P1-6 (BRAKE) - This is the Remote Input Brake terminal. When this terminal is connected to common, the motor will stop.
- P1-7 (RELAY_COM) – Relay common contact.
- P1-8 (S3) – This is the Sensor 3 input from the motor.
- P1-9 (P3) – Phase 3 of the motor is connected to this terminal.
- P1-10 (P1) - Phase 1 of the motor is connected to this terminal.
- P1-11 (P2) – Phase 2 of the motor is connected to this terminal.
- P1-12 (+5V) – This is a self-contained +5VDC power supply capable of up to 50mA. The speed sensor supply lead can be connected to this terminal for its power source.
- P1-13 (RELAY_NC) – Relay normally closed contact.
- P1-14 (RELAY_NO) – Relay normally open contact.
- P1-15 (S1) – This is the Sensor 1 input from the motor.
- P1-16 (S2) – This is the Sensor 2 input from the motor.

Hook-up Overview

Groschopp Brushless DC motors have eight (8) wires: three (3) stator (phase) wires, three (3) motor sensor wires, and two (2) wires for sensor power and sensor common. Groschopp BLDC motors are designed using 120° sensor configurations.

Groschopp BLDC motors should be connected to the DB2110D-2 as shown in the hook-up diagram. The power should be off until the hook-up procedure is complete.

12V/24-48VDC Voltage Jumper

There is a jumper on the bottom PCB of the control for different DC input voltage settings. This jumper is used with a 3 pin header, JP1. If the DC supply voltage is nominally 12VDC, place this jumper in the 2 pins of JP1 that are close to the "12V" position. If the DC supply is greater than 20V, but less than 50V, place the jumper close to the "24/48V" position.

60°/120° Sensor Spacing Jumper

There is a jumper on the control to switch between 60° and 120° hall sensor spacings. This jumper is used with a 3 pin header, JP2. Place this jumper in the 2 pins of JP2 that are close to "60" position for 60° operation, or in the 2 pins of JP2 that are close to "120" position for 120° operation.

FWD/REV Jumper

There is a jumper on the bottom board of the control for reversing the direction of the motor. This jumper is used with a 3 pin header, JP3. After initial turn on of the motor, if the motor shaft is rotating in the wrong direction, stop the motor and change the location of the jumper to the other unused jumper pin and center pin of JP3.

Hook-up Procedure for Groschopp BLDC Motors

Locate Groschopp drawing AS-190 ("Motor Connection Diagram - Brushless DC Motor"). These diagrams in AS-190 show the sequencing of the Hall sensor outputs as related to the three motor phases.

Return to the section "60°/120° Sensor Spacing" (above) and make sure the control is set to 120°. Return to the correct wiring diagram and connect the sensors to terminals S3, S2 and S1 of P1.

After the sensors are connected, attach the sensor power line to terminal 5V of P1. The sensor common line is connected to terminal COM of P1. Now attach the three motor armature wires and test for proper hook-up.

We recommend arbitrarily attaching the phase lines to terminals P1, P2, and P3 of connector P1. Choose a configuration, test it, and then keep track of the results on paper.

Now apply power to the control. Slowly increase the speed setting by pressing the "UP" arrow. Watch for erratic rotation or excessive source current. If either occurs, immediately press the "DOWN" arrow to reduce speed, and turn off the power. Refer back to the hook-up diagram and make sure the motor and drive are correctly connected.

Adjustments

Current Limit

Groschopp has factory set the Current Limit to 125% of 8.0 Amps DC. The setting should not need to be increased. If the current limit needs to be set to a lower value, do so by adjusting the Current Limit trimpot (CL) CCW until the desired setting is achieved.

Setting Current Limit

Current Limit should normally be set to approximately 125% of the FLA rating of the motor that is running. To set current limit for the specific motor or application, follow these steps while monitoring motor current:

- 1) Preset Current Limit trimpot (CL) fully CW.
- 2) Run motor at full or normal running speed.
- 3) Load motor to 125% of its FLA rating or the desired maximum load.
- 4) Measure the DC input current with an analog DC current meter placed in series with the positive DC input lead.
- 5) Decrease the Current Limit trimpot setting until the motor current begins to drop, and then slowly increase the setting until just reaching the desired maximum current as obtained in step 3.

Note: Do not use the Current Limit trimpot as a torque control or to reduce the speed of a motor.

Internal Fault LED

The internal fault LED (Red) indicates that there is a fault condition present with the control. One or several of the following fault conditions can be present: invalid sensor input code, 60°/120° phasing jumper in wrong position, over current condition (i.e. Current Limit set too low), undervoltage lockout (i.e. +12V supply is less than 10.0V) or thermal shutdown (i.e. U4 is too hot). Typical fault conditions are: invalid sensor attachment, 60°/120° phasing jumper is in the wrong position, or Current Limit is set too low.

Basic Operating Instructions

Control Algorithm Discussion and P-I-D Tuning

A true P-I-D speed control algorithm is employed in the DB2110D-2 which allows precise and quick response to set speed or load changes. The three items, 26, 27 and 28 (Proportional, Integral, Derivative, respectively) are adjustable as shown on page 16. P-I-D can be tuned to get precise speed response and regulation.

When adjusting P-I-D, begin by using the factory defaults the control is preset to: P (Item 26) to 90, I (Item 27) to 15, D (Item 28) to 2. If further adjustment of P-I-D is needed, follow the steps below.

To adjust P: (Item 26)

Run the motor from zero speed to the set speed. If the start up response of the motor is too slow, increase "P" in increments of 20 until the desired start up response time is obtained. If the start up response time is too fast, decrease "P" in increments of 10 until the desired response is reached. "P" is used to adjust the start up response time only. The start up response time is approximately 0 to 60% of the set speed. "I" can be used if adjustment of the upper response time (60 to 100% of the set speed) is needed.

To adjust I: (Item 27)

Run the motor from zero speed to the set speed. If the upper response time (60 to 100% of the set speed) has any hesitation or has too slow of a response, then increase "I" in increments of 5 until the

hesitation is eliminated and/or the desired upper response time is obtained. If the upper response time is too fast or has too much overshoot, decrease "I" in increments of 3 until the overshoot is eliminated and/or the desired upper response time is reached.

To adjust D: (Item 28)

"D" can be used to dampen the effect of "P". By making "D" too large, the response time of the control can be reduced, so keep "D" as small as possible on non-regenerative controls.

Note: The proportion of P-I-D seems to be more critical than the individual values, i.e.. values of 50-50-50 will achieve virtually the same results as 999-999-999.

Rate and Time Mode Explained

In Rate Mode, the BLDC controls the rate of the motor by tracking the motor's pickup pulses which are applied to Sensor Input A (SA). In this mode, the display indicates in rate units such as Gallons-per-minute, feet-per-second, or RPM.

In Time Mode, the BLDC controls the process time by tracking the motor's pickup pulses which are applied to Sensor Input A (SA). In this mode, the display indicates in time units such as HH:MM or MM:SS, where HH is hours, MM is minutes, and SS is seconds. This mode is most-commonly used in time-sensitive processes such as conveyor ovens and plating applications.

Visual Reference

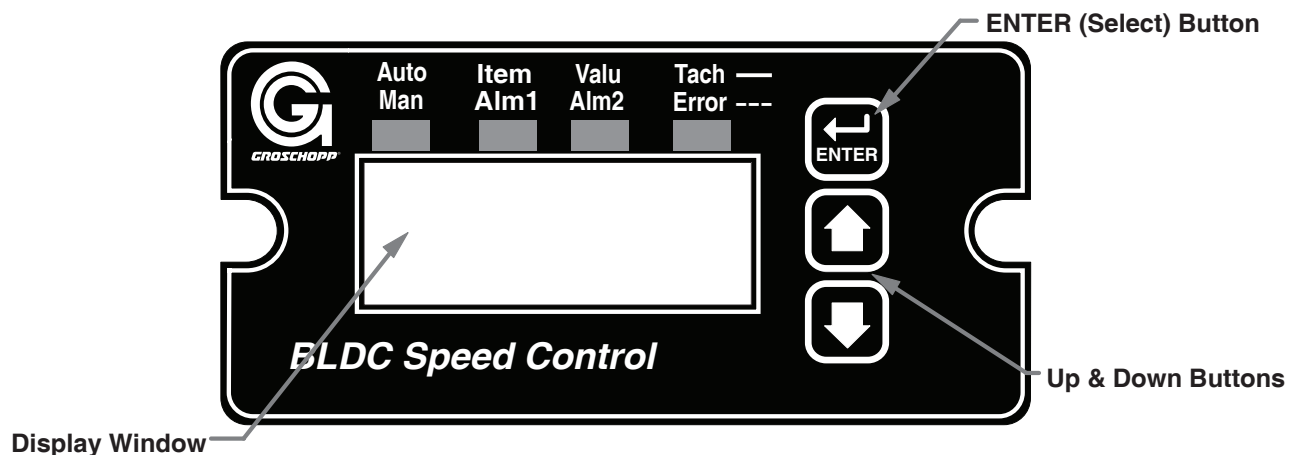

How to Change an Item's Value (The Short Story)

1. Hold down the Enter button until Item-Selection Mode is entered. The 'Item' Annunciator will light
2. Using the Up and Down buttons, select the desired Item number to view or edit
3. Press the Enter button to change the value of the Item. The 'Valu' Annunciator will light
4. Using the Up and Down buttons, change the Item's value as desired
5. Press the Enter button to permanently save the changes (Returns to Item-Selection Mode)
6. Select Item Zero ("0") and press the Enter button to return to Running Mode

Operating the User Interface (The Long Story)

Although the DB2110D-2 user interface is very versatile, it is also simple to setup and operate. With just a few button presses, it allows the user to configure a number of adjustable Items. The LED display has three basic operating modes: Running Mode, Item-Selection Mode, and Value Mode. "Item" and "Value" modes also have specific visual indicators (LED "Annunciators") that allow the user to immediately determine the current state or mode of the user interface. **Note: Item-Selection Mode (and Value Mode) can only be entered if the Program Enable jumper is in the "On" position.**

Running Mode is the default display of the unit when power is applied. The DB2110D-2 will spend the majority of its time in this mode. In Running Mode, the display shows the Target or Actual ("Tach") speed value in the user-defined Engineering Units format for rate or time. The control will continuously attempt to drive the motor to the requested Target. In this display mode, the Up and Down buttons increase or decrease the displayed target value until either the display minimum or display maximum limit is reached. Depending on the alarm configuration, these buttons may also serve as an alarm-silence or alarm-reset button. For example, displays for rate and time operating modes could be 13.60 and 45:30 respectively.

Item-Selection Mode can be entered by simply pressing and holding the Enter button down for about three seconds. Once in Item-Selection Mode, the "Item" Annunciator will illuminate. The display will indicate the currently selected Item number for editing purposes. Pressing the Up or Down button will increase or decrease the selected Item number on the display. Although the Item numbers are in numerical order, some numbers are skipped. These numbers represent reserved Items that are not yet implemented and are not displayed.

Further, Item numbers above 999 are actually located on the ModularBus card(s) that are installed in the "Host" Drive. The numbering scheme is the ModularBus "slot number (100, 200 or 500) times 10, plus the Item Number. Once the desired Item number is displayed, a press of the Enter button will change the display to the Value Mode. So, for example, to view/edit Item 20 on a ModularBus card in Slot 200, "Browse" to Item number 2020 (200 X 10 + 20).

When in Item-Selection Mode, pressing the Enter button with Item 0 selected will cause the unit to return to Running Mode. See the Software Items for a list of available Items.

Value Mode is used to modify the value of the selected Item. When in Value Mode, the "Valu" Annunciator will illuminate. Pressing the Up or Down button increases or decreases the selected Item's value. With only one exception, value changes take effect immediately. For example, when adjusting P-I-D settings, the change in response can be observed "live", which greatly facilitates the P-I-D "tuning" process. Once the desired value is showing in the display window, pressing the Enter button again will return to Item-Selection Mode and the new value will be saved in permanent memory. Removing power from the unit while in Value Mode will result in the specified new value being lost, and the previous (old) value being used. This can be used as an "undo", for example, during editing a value that is being edited in the wrong Item. **Note: Changes to Item 10, Operating Mode, do not take effect until power is removed and re-applied to the DB2110D-2.**

Detailed Configuration Instructions

Default Configuration

When shipped from the factory, the following basic settings are in place:

Rate Mode Operation in RPM

Sensor Pulses per Revolution: 2 (4 poles)

Decimal Point Display: Off

Display Range: 0 - 2400

Speed Range: 0 - 2400 RPM

Accel and Decel: 2500 RPM per second

Alarm Output: Disabled

Resetting the Unit to Factory Defaults

The factory-default settings can be easily restored using either of two methods. Both methods require the Program Enable jumper to be in the "On" position. The first is to apply power to the unit with both the Enter and Down buttons pressed for 3 seconds. The second is to change the value of parameter 95 to 5.

JP1 (Program Enable Jumper)

The JP1 jumper is located under the dust cover on the back end of the upper board. When the jumper is set to the "Off" position, all programming features are locked out to the front panel user. When the jumper is in the "On" position, the programming parameters are open to change. JP1 is shipped from the factory set in the "On" position.

Setting and Reading "SoftSwitches"

Like many other devices, the DB2110D-2 has the ability to select between a number of "yes/no" or "on/off" options, depending upon the application. Traditionally, this sort of option-selecting was done with some sort of physical switch or switches (such as a "DIP switch"), or by other means, such as the "jumper block" used to enable/disable Programming on the DB2110D-2. There are two problems with this approach to option-selection: 1) Both DIP switches and "jumper blocks" are physically large, and most require that the device be at least partially disassembled to gain access to them; 2) On a device with more than just a very few options, the number and combinations of switches quickly becomes overwhelming.

Because of these drawbacks, the DB2110D-2 takes a different approach (where appropriate): SoftSwitches.

It is easiest to think of an Item containing SoftSwitches as a DIP switch containing from one to thirty-two switches. But instead of actually flipping a switch "on" or "off", you can set and read these "switches" as a *Binary-Coded-Decimal*, or "BCD" number. Now, before you say "Binary numbers! Those are for computers!", let's look at this another way. Each "switch", from #1 through #32, has been assigned a decimal number that represents its position in the make-believe DIP switch assembly. When that number is used, it means that the switch is "on". For example, the decimal number that represents switch #4 is 8, the number that represents switch #6 is 32, and so on. See the table below for a full explanation of these values. Note: Due to display limitations, switches 15 through 32 are currently unused.

Switch#	BCD Value	Switch#	BCD Value
1	1	8	128
2	2	9	256
3	4	10	512
4	8	11	1024
5	16	12	2048
6	32	13	4096
7	64	14	8192

So, the **Binary-Coded-Decimal (BCD) number contained in a SoftSwitch Item is nothing more than the *sum* of the numbers representing the "on" switches.** For example, if you wanted to set switches #1, #4, and #7 to the "on" position, you would place the number 73 (1 + 8 + 64) into the Item containing those SoftSwitches; if you wanted to set switches #5 and #6 "on", you would place the

number 48 (16 + 32) into the Item, and so forth. **Simply "add-up" the BCD values of the switches you wish to "turn on", and place the total, or "sum", into the Item containing the SoftSwitches.**

The settings of the SoftSwitches can also be read the same way: For example, if an Item containing the SoftSwitches has been set to the number 11, you can tell that switches #1, #2 and #4 are "on". You can tell this by *subtracting* the BCD values, from highest to lowest, *starting at the highest value that is less than or equal to the "total"*. Keep subtracting, but if you get a negative number as a result, then don't subtract that BCD value (add it back in before proceeding). Work your way "downward" in this manner toward Switch #1, but when your total reaches zero, you are finished.

Try a few examples of your own, and very soon you will be easily setting and reading SoftSwitches.

Setting and Reading "Alarm" Conditions

Taking advantage of the "SoftSwitches" feature described on last page, the DB2110D-2 Series is equipped with *two* "Alarm" outputs, which can be independently set to Activate on any of 16,384 possible combinations of "conditions" or "events" that could be occurring at any one time. See table below for a list of these Condition "Flags".

The conditions are logically "OR-ed" together to form the particular Alarm output. If the SoftSwitches for the "Tach Outside Limits" and the "Sensor Input Stalled" Conditions for Alarm1 are set to "On", then Alarm1 will be "true" when either one or both of those Conditions are "true". However, for even more flexibility, each condition can be combined in a logical "AND" fashion to "override" the Alarm output.

Additionally, each Condition can be "inverted" before being sent to the "AND" function, for even greater flexibility. Please note that if a particular Condition is inverted, the corresponding "switch" in the appropriate "AND" Item (52/72) is inverted as well.

Further, setting any of the "Softswitch" Items in the OR/Invert/AND Alarm Conditions (Items 50-52 and 70-72) to a value of zero effectively removes the effect of their "logic" from the "Circuit". Therefore, even though the Alarm logic conditions are "cascaded" OR -> Invert -> AND, if, for example, the application does not need any "AND" conditions, simply set the value of the AND Item 52 and/or 72 to zero, and the "AND" function will be "jumped around". In that case, however, it would also be best to set the "Inverter" Item (51 and/or 71) to zero as well.

Table: BCD Values for Drive Condition "Flags"

BCD Value	Description
0	(No Flags are currently Active)
1	Accel/Decel Ramp In Progress
2	S1 (Main) Actual Speed (Tach) is Outside Alarm Limits
4	Target Speed is Outside Alarm Limits
8	Target Speed = 0
16	Sensor Input is Stalled
32	Reserved
64	Jog Function is Activated
128	Inhibit Function is Activated
256	E-Stop Function is Activated
512	Drive is at Maximum Output
1024	"Run" Condition
2048	Slot 100 Alarm1 Activated (Valid only if ModularBus card installed in this slot)
4096	Slot 200 Alarm1 Activated (Valid only if ModularBus card installed in this slot)
8192	Slot 500 Alarm1 Activated (Valid only if ModularBus card installed in this slot)

"Alarm" Output Routing

The "output" of Alarm1 is permanently "routed" to drive the Form-C Relay output on the DB2110D-2 itself (see Hook-up Diagram, P1-7, P1-13, and P1-14). The "output" of Alarm2, however, can be *Routed* (through the use of Item 81) to any one of the three ModularBus "slots", 100, 200 or 500.

DB2110D-2 Alarm "Logic"

Note: The "circuitry" shown below is actually implemented in software, not hardware, and although it makes little difference to the final output produced, that fact should be kept in mind.

Also note that the "switches" on the outputs of the "OR gate", the "AND gate", and the "Implied" AND gate are only under *indirect* user control. That is, they are set "automatically" by the action of other settings that *are* under user control. For example, the "switch" on the output of the "OR gate" is *automatically* set to the "uppermost" position (as shown on the drawing, below) when Item 50 is set to zero."

Often there is more than one way to "connect" the signals and "logic" to achieve the desired result. But determining the proper signal "polarity" to use is *often* a tricky problem in "logic circuits". Sometimes it takes a bit of careful planning to arrange "inverted" and "non-inverted" signals properly. Also, keep in mind that standard logic "tricks", such as the use of "Negative Logic" techniques, can be used to further expand your options. See the Application Example on page 31 for further details.

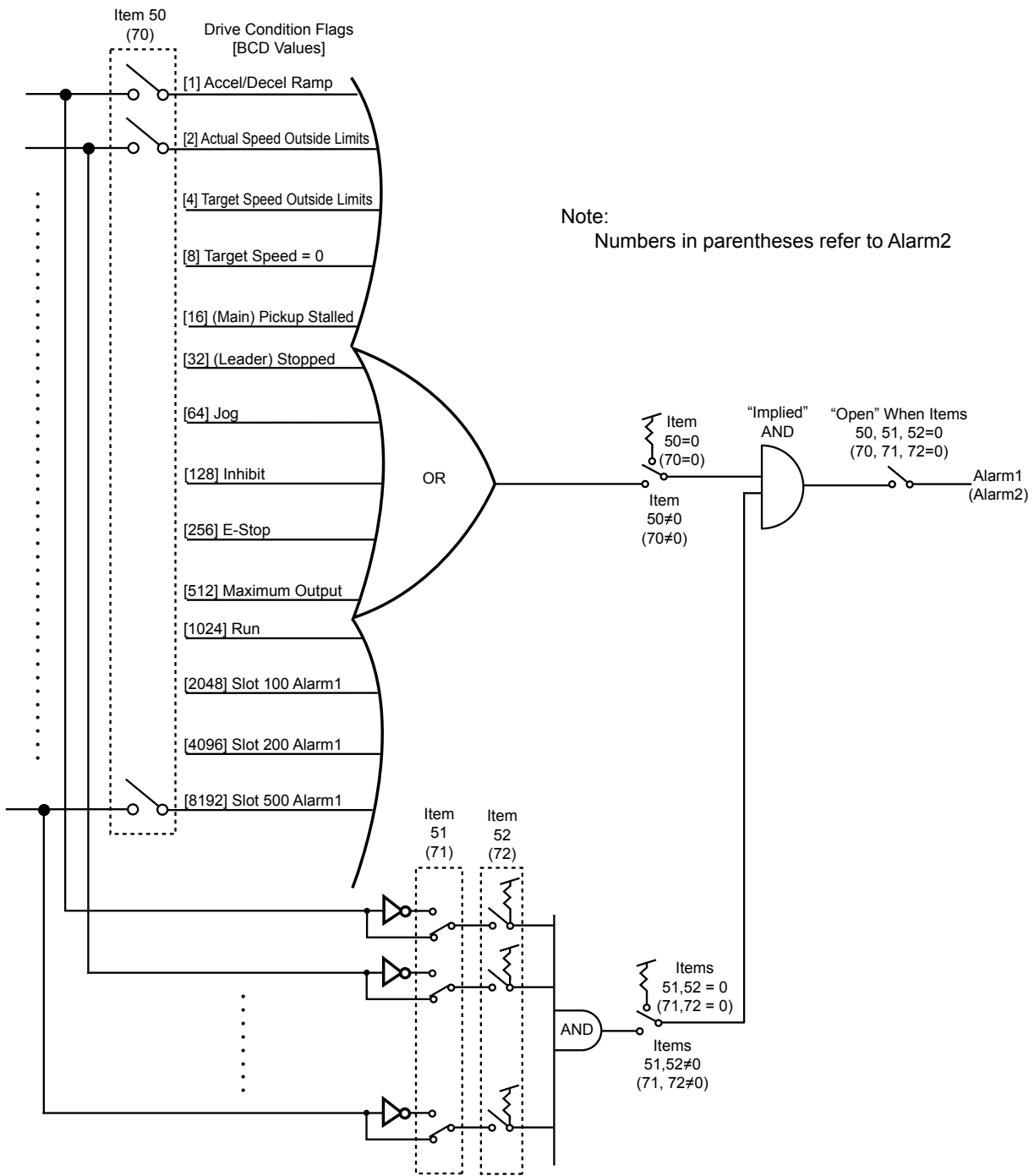

Software Parameters (Items)

Item	Description	Value Range	Units	Factory Default	User Setting
0	Selecting this item exits to "Run" Mode	n/a	—	n/a	n/a
Read-Only Items					
1	Model Number	47 = DB2110D-2	—	47	
2	Software Version	1 – 9999	—	n/a	
3	Hardware Version	1 – 9999	—	n/a	
4	DartNet Version	1 – 9999	—	n/a	
5	Serial Number (Major)	0 – 9999	—	n/a	
6	Serial Number (Minor)	0 – 9999	—	n/a	
8	Drive Condition Flags	(See "Flags" Table, pg. 5)	BCD	n/a	
General Setup Items					
10	Operating Mode	1 = Rate Mode 2 = Time Mode	—	1	
11	Display Brightness	0 – 31 (Dim – Bright)	—	26	
12	Display Mode	1 = Target Speed Display 2 = S1 Actual Speed Display	—	1	
13	Decimal Point Position	0 = D.P. Disabled [XXXX] 1 = [X.XXX] 2 = [XX.XX] 3 = [XXX.X] 4 = [XXXX.]	—	0	
14	Keypad Mode	1 = Linear, Constant Rate 2 = Non-Linear, Accelerating Rate	—	2	
15	Keypad Scroll Delay	0 – 30 (Fast – Slow)	—	10	
16	Power-up Target Speed	1 = Force Zero Speed 2 = Force Power-up Value 3 = Use Previous Target Speed	—	3	
17	Power-Up Value	0 – 9999	(Eng. Units)	0	
18	Front-Panel DoubleClick Destination	0 = DoubleClick <i>Ignored</i> 1 = Inhibit 2 = EStop 3 = Jog	—	0	
19	Reserved				
Control Loop Items					
20	Display Minimum	0 – 9998	(Eng. Units)	0	
21	Display Maximum	1 – 9999	(Eng. Units)	3600	
22	Motor Control Method	0 = Gain Tracking Off, Low Speed Mode Off 1 = Gain Tracking On, Low Speed Mode Off 2 = Gain Tracking Off, Low Speed Mode On 3 = Gain Tracking On, Low Speed Mode On 4 through 32 DO NOT USE!	—	1	
23	Accel Setting	1 – 9999	(Eng. Units)	9999	
24	Decel Setting	1 – 9999	(Eng. Units)	9999	
26	Proportional Gain	0 – 9999	—	90	
27	Integral Gain	1 – 9999	—	15	
28	Derivative Gain	0 – 9999	—	2	
29	Reserved				

Software Parameters (Items), cont'd

Item	Description	Value Range	Units	Factory Default	User Setting
Signal Input #1 Setup Items					
30	Sensor Input Display Reference	0 – 9999	(Eng. Units)	2400	
31	Sensor Input Reference RPM	0 – 9999	RPM	2400	
32	Sensor Input Pulses Per Revolution	1 – 9999	PPR	2	
33	Sensor Input Initial Stall Timeout	0, 5 – 9999 (0 = Defeat)	Sec.	0	
34	Sensor Input Running Stall Timeout	0 – 999.9 (0 = Defeat)	1/10 Sec.	0	
35	Reserved				
36	Jog Set Point	1 – 9999	(Eng. Units)	1000	
37	Reserved				
38	Reserved				
40	Reserved				
41	Reserved				
42	Inhibit Configuration	0 = No Accel/Decel 1 = Decel Only, No Accel 2 = Accel Only, No Decel 3 = Both Accel and Decel	—	0	
Alarm Output #1 Setup Items					
50	Alarm1 Logical “OR” Activation Conditions	(See “Flags” Table, pg. 5)	BCD	0	
51	Alarm1 Logical Inverters	(See “Flags” Table, pg. 5)	BCD	0	
52	Alarm1 Logical “AND” Activation Conditions	(See “Flags” Table, pg. 5)	BCD	0	
53	Alarm1 Output Style & Reset Mode	1 = Constant & Auto-Reset 2 = Constant & Manual Reset 3 = Pulsed & Auto Reset 4 = Pulsed & Manual Reset	—	1	
54	Alarm1 Reset Configuration	1 = No Silence, Reset on Enter But. 2 = Reserved 3 = Reserved 4 = Silence & Reset on Enter But. 5 = Reserved 6 = Reserved	—	1	
55	Annunciator Alm1 Flash On Active Alarm1	0 = No Annunciator Flash 1 = Annunciator Flash	—	0	
56	Alarm1 Output Pulse “ON” Time	1 – 3600	Secs.	1	
57	Alarm1 Output Pulse “OFF” Time	1 – 3600	Secs.	1	
58	Alarm1 Output Pulse Count	0 – 9999	—	0	
59	Alarm1 Lower Limit	0 – 9999	(Eng. Units)	0	
60	Alarm1 Upper Limit	0 – 9999	(Eng. Units)	9999	

Software Parameters (Items), cont'd

Item	Description	Value Range	Units	Factory Default	User Setting
Alarm Output #2 Setup Items					
70	Alarm2 Logical "OR" Activation Conditions	(See "Flags" Table, pg. 15)	BCD	0	
71	Alarm2 Logical Inverters	(See "Flags" Table, pg. 15)	BCD	0	
72	Alarm2 Logical "AND" Activation Conditions	(See "Flags" Table, pg. 15)	BCD	0	
73	Alarm2 Output Style & Reset Mode	1 = Constant & Auto-Reset 2 = Constant & Manual Reset 3 = Pulsed & Auto Reset 4 = Pulsed & Manual Reset	—	1	
74	Alarm2 Reset Configuration	1 = No Silence, Reset on Enter But. 2 = No Silence, Reset on S2 High 3 = No Silence, Reset on S2 Low 4 = Silence & Reset on Enter But. 5 = Silence & Reset on S2 High 6 = Silence & Reset on S2 Low	—	1	
75	Annunciator Alm2 Flash On Active Alarm2	0 = No Annunciator Flash 1 = Annunciator Flash	—	0	
76	Alarm2 Output Pulse "ON" Time	1 – 3600	Secs.	1	
77	Alarm2 Output Pulse "OFF" Time	1 – 3600	Secs.	1	
78	Alarm2 Output Pulse Count	0 – 9999	—	0	
79	Alarm2 Lower Limit	0 – 9999 (Eng. Units)	(Eng. Units)	0	
80	Alarm2 Upper Limit	0 – 9999 (Eng. Units)	(Eng. Units)	9999	
81	Alarm2 Output Routing	1 = Reserved 2 = Use Slot 100 Alarm1 Output 3 = Use Slot 200 Alarm1 Output 4 = Use Slot 500 Alarm1 Output	—	3	
Item Memory Commands (Actions)					
95	Restore MD40/50 Settings to Factory Defaults (affects Drive Settings Only)	0 = Do Nothing & Exit 5 = Restore Factory Defaults	—	0	n/a
96	Restore ModularBus Card(s) Settings to Factory Defaults (Card(s) Settings Only)	0 = Do Nothing & Exit 100 = Restore Slot 100 Defaults 200 = Restore Slot 200 Defaults 500 = Restore Slot 500 Defaults	—	0	n/a
98	Save "Environment" (Drive and ALL ModularBus Card(s) Settings) to "User Save" storage area	0 = Do Nothing & Exit 5 = Copy <u>current</u> Settings TO Settings2 (or Settings1 if currently using Settings2)	—	0	n/a
99	Restore/Swap "Environment" (Drive and ALL ModularBus Card(s) Settings) from "User Save" storage area	0 = Do Nothing & Exit 5 = <u>Copy</u> (Restore) <u>current</u> Settings FROM Settings2 (or Settings1 if currently using Settings2) 10 = <u>Swap</u> Between Settings1 & 2	—	0	n/a

Item (Parameter) Descriptions

Item 0 – Exit to Running Mode

When Item 0 is selected in Item-Selection Mode, the unit will return to Running Mode and, depending on the value of Item 12, will display the running (Target) or actual (Tach) value. This should be selected once changes to Items are completed.

Item 1 – Model Number (Read Only)

This number represents the base model number for the product. The model code for the DB2110D-2 Series is 47. In this manual, where appropriate, the “Drive” portion of these products are referred to as the “Brushless Control”.

Item 2 – Software Version (Read Only)

The software version is a code which identifies the software “build number” of the unit.

Item 3 – Hardware Version (Read Only)

The hardware version is a code which identifies which hardware was used to build the unit.

Item 4 – ModularBus Protocol Version (Read Only)

The ModularBus protocol version is a code which identifies the *highest* (most-recent) version of the ModularBus protocol with which this unit is compatible.

Item 5 & 6 – Serial Number, Major & Minor (Read Only)

These Items are reserved for future use as an electronic serial number and are unique to each manufactured unit.

Item 8 – Drive Condition Flags (Read Only)

This is a Binary Coded Decimal (“BCD”) representation of the currently active “Flags” representing certain real-time conditions and/or modes in which the drive is operating. This display is updated several times per second to reflect the up-to-the-second status of the drive and its ModularBus cards, if any. See “Flags” table on page 14 for the BCD values.

Item 10 – Operating Mode

This Item defines the operating mode for the entire unit. The unit controls the load using either rate or time units.

NOTE: Power must be removed and re-applied to the Brushless Control for a change in Operating Mode to take effect. It is also strongly suggested the Target Speed be reduced to zero and the setting of Items 16, 17, 20, 21, 30 & 31 be reviewed carefully prior to doing so.

The following Operating Modes are available for the Brushless Control:

Mode 1 – Rate Mode

In Rate Mode, the Brushless Control displays in user-defined rate “Engineering Units” such as RPM, Gallons per Hour, or Feet per Second.

Mode 2 – Time Mode

In Time Mode, the Brushless Control displays in time units using the format AA:BB. By default AA:BB represents minutes (AA) and seconds (BB). Optionally, it can be configured to represent hours (AA) and minutes (BB) or other user-defined units with a 1:60 relationship. When setting Items which are configured in engineering units, the programmed value is determined by the formula $(AA * 60) + BB$. In HH:MM displays, this is the total number of minutes. In MM:SS displays, this is the total number of seconds.

Item 11 – Display Intensity

This Item adjusts the intensity of the LED display digits in the front panel of the unit. The values of 0 – 31 correspond to a gradual change from very dim to very bright. This is often useful when the Brushless Control is used in the same panel as other pieces of equipment with LED displays and a uniform display brightness is desired. Simply adjust the Brushless Control to match its surroundings.

Item 12 – Display Mode

This Item selects what the DB2110D-2 Series will show on its display during Run Mode. Note that it can “toggle” between whatever the Display Mode is set to and its “opposite” by briefly pressing and releasing the ENTER button. For example, if this Item is set to 1 (Target Speed/Time), pressing the ENTER button will briefly show the Actual (Tach) Display (and illuminate the “Tach” LED Annunciator). Conversely, if this Item is set to 2 (Main Tach), pressing the ENTER button will briefly show the Target Speed/Time.

The following Display Modes are available for the Brushless Control:

Mode 1 – Target Speed/Time Display

In Rate Mode, the Brushless Control displays the Target Speed in user-defined rate Engineering Units such as RPM, Gallons per Hour, or Feet per Second. In Time Mode, the Brushless Control displays the Target Time in time units using the format AA:BB.

Mode 2 – S1 Actual Speed (Tach) Display

In Rate Mode, the Brushless Micro-Drive displays the Actual Speed in user-defined rate Engineering Units such as RPM, Gallons per Hour, or Feet per Second. In Time Mode, the Brushless Control displays the Actual Time in time units using the format AA:BB.

Item 13 – Decimal Point (DP) Position (used in Rate Mode Only)

This selects the format of the display with respect to the decimal point's position. This Item does not effect the value entry for other Items. For example, if the user desires to display 10.00 at 300RPM, then Item 30 would be set to 1000, Item 31 would be set to 300, and Item 13 would be set to 2.

Mode 0: Fixed XXXX

Mode 1: Fixed X.XXX

Mode 2: Fixed XX.XX

Mode 3: Fixed XXX.X

Mode 4: Fixed XXXX.

Item 14 – Keypad Mode

This Item selects the operating mode of the front-panel push buttons. In some applications, increasing or decreasing the scroll rate provides the user more controllability when entering settings. Items 14 and 15 affect only the Up and Down buttons when the user interface is in Running Mode. These settings also apply to remote Up / Down buttons which are attached via the -1 option board.

Mode 1: Linear, Constant Rate

In linear mode, pressing and holding the Up or Down buttons will cause the display to continuously change value in the requested direction until either the Display Minimum or Display Maximum is reached. The displayed value will scroll at a constant rate which is specified using Item 15.

Mode 2: Non-linear, Accelerating Rate

In non-linear mode, pressing and holding the Up or Down buttons will cause the display to continuously change value in the requested direction until either the Display Minimum or Display Maximum is reached. The displayed value will initially scroll at a slow rate and increase in speed until the maximum scroll rate is achieved. The initial scroll rate is specified using Item 15.

Item 15 – Keypad Scroll Delay

This Item sets the scroll speed for the front-panel push buttons. The function of this Item varies slightly depending on the Keypad Mode. See Item 14 for more details.

Item 16 – Power-up Target Speed

This Item determines the default Running Value when power is initially applied to the Brushless Control.

Mode 1: Default to Zero

When in this mode, the unit will default to zero (engineering units).

Mode 2: Default to Power-Up Value

When in this mode, the unit will default to the Power-up Value, Item 17.

Mode 3: Default to Previously Running Value

When in this mode, the unit will default to the previous running value before power was removed. A previous running value must have been active for at least 3 seconds to be recalled after power has been disconnected and reapplied.

Item 17 – Power-up Value

When Power-up Mode is set to 2, this Item will designate the default display value at power-up in the user's desired units of measure ("engineering units"), e.g. RPM, GPM, FPM, etc.

Item 18 – Front Panel DoubleClick Routing

This Item determines what happens if the user "Double-Clicks" the Enter Button (two button presses quickly) on the front panel of the Brushless Control.

Mode 0: DoubleClick Ignored

When in this mode, DoubleClicking on the Enter Button will have no effect.

Mode 1: Route DoubleClick to Inhibit

When in this mode, Double-Clicking on the Enter Button with the drive "running" will place the Drive in Inhibit. **Note that the DoubleClick action works as a "toggle".**

Mode 2: Route DoubleClick to EStop

Same as Mode 1, but DoubleClick is Routed to the E-Stop function.

Mode 3: Route DoubleClick to Jog

Same as Mode 1, but DoubleClick is Routed to the Jog function, causing the control to temporarily run at the Target Speed in Item 36. See, also, Item 36.

Mode 4: Reserved

Item 20 – Display Minimum

This Item defines the lower end of the display range. This is the value which limits how low the user is able to scroll the displayed value in Running Mode. In Rate and Time modes, this value is set in engineering units.

Item 21 – Display Maximum

This Item defines the upper end of the display range. This is the value which limits how high the user is able to scroll the displayed value in Running Mode. In Rate and Time modes, this value is set in engineering units.

Item 22 – Motor Control Method

This Item controls two behaviors in the Brushless Control, Low-Speed "Gain-Tracking", and Ultra-Low-Speed Control Mode ("gearbox" mode). When set to a value of 1 (or 3), this item automatically (and proportionally) reduces the "gain" of the PID values when the Target Speed (in RPMs) is less than 200. This greatly increases the overall stability at low speeds in applications that require a very wide range of Target Speeds, without having to unduly compromise control responsiveness at higher speeds. When set to a value of 2 (or 3), this Item adjusts the speed-control characteristics of the Brushless Control to enhance the smoothness of speed control when in a situation where the "tach pickup" must be installed on the "low speed side" of a very slowly turning gear-motor output shaft. A rule of thumb would probably be to consider enabling this Mode if the shaft is turning less than 10 RPM, and the pickup produces less than 10 Sensor Input Pulses Per Revolution. Use this Mode only if speed stability can not be achieved by adjusting the PID settings (Items 26 – 28).

Mode 0: Disabled

Both Low-Speed-Gain-Tracking and Ultra-Low-Speed Control Mode are defeated.

Mode 1: Low-Speed-Gain-Tracking (Only) Enabled

Low-Speed-Gain-Tracking is enabled, Ultra-Low-Speed Control Mode is defeated.

Mode 2: Ultra-Low-Speed Control Mode (Only) Enabled

Low-Speed-Gain-Tracking is defeated, Ultra-Low-Speed Control Mode is enabled.

Mode 3: Low-Speed-Gain-Tracking and Ultra-Low-Speed Control Mode (Both) Enabled

Both Low-Speed-Gain-Tracking and Ultra-Low-Speed Control Mode are enabled.

Item 23 – Acceleration Setting

This Item determines how fast the Brushless Control will accelerate toward the displayed target setting. This Item is set in engineering units of change per second, such as RPM, GPM, or feet per second.

Item 24 – Deceleration Setting

This Item determines how fast the Brushless Control will decelerate toward the displayed target setting. This Item is set in engineering units of change per second, such as RPM, GPM, or feet per second.

Item 26 – Proportional (P) Gain

The Proportional Gain is the first of three Items which define the responsiveness of the control with respect to how fast it responds to changing loads. Because the Brushless Control controls are true velocity-form PID control, the higher the P Gain, the more aggressively the unit will respond to a change in load or target speed. See the “Basic Operating Instructions” section of the manual for more details.

Item 27 – Integral (I) Gain

The Integral Gain is the second of two Items which define the responsiveness of the control with respect to how fast it responds to changing loads. The higher the I Gain, the more aggressively the unit will drive the load. However, it will sometimes be necessary to decrease the I Gain and/or increase the P Gain to prevent unwanted oscillation and instabilities. See the “Basic Operating Instructions” section of the manual for more details.

Item 28 – Derivative (D) Gain

The Derivative Gain is the third of the three Items which define the responsiveness of the control with respect to how fast it responds to changing loads. Although most applications will run fine with the D Gain set to zero, sometimes adding a little “D” will help minimize overshoot and undershoot. See the “Basic Operating Instructions” section of the manual for more details.

Item 30 – Sensor Input (S1) Display Reference

This is **the number to be displayed when at the user-specified motor Reference RPM**. In Rate Mode, this value represents rate units such as feet, ounces, or revolutions. In Time Mode, this value represents the reference time measured in seconds or minutes. If the desired display is HH:MM, then all values should be entered in minutes. If MM:SS is desired, then all values should be entered in seconds.

Item 31 – Sensor Input (S1) Reference RPM

This is the **reference RPM at which the Display Reference value should be displayed**. In Rate and Time Modes, this value represents the RPM of the encoder to which the Display Reference corresponds.

Item 32 – Sensor Input (S1) Pulses per Revolution

This is the number of sensor pulses per revolution for the sensor input (S1). The number of sensor pulses per revolution is half of the number of motor poles. The Brushless Control supports sensors and encoders from 1 to 9999 pulses per revolution.

Item 33 – Sensor Input (S1) Initial Stall Timeout

When the Target Speed is above zero RPM, this Item determines the maximum time in units of seconds that can elapse before the *first* S1 sensor pulse before the Brushless Control considers itself in a “Stall” Condition. It is not advisable to set this lower than approximately 10 seconds (a value of 10), or it may be difficult to achieve startup in a low-speed application. A value of zero defeats this timeout. (Note: This parameter will only work if the alarm is set for stall on any of the items 50, 51, or 52.)

Item 34 – Sensor Input (S1) Running Stall Timeout

When the Target Speed is above zero RPM, this Item determines the maximum time in units of 0.1 Seconds that can elapse between S1 sensor pulses before the Brushless Control considers itself in a “Stall” Condition. It is not advisable to set this lower than approximately 10 seconds (a value of 100), or it may be difficult to achieve startup in a low-speed application. Also note that the S1 Pulses Per Revolution (PPR) must be taken into account when determining the proper setting for this timeout. A value of zero defeats this timeout. (Note: This parameter will only work if the alarm is set for stall on any of the items 50, 51, or 52.)

Item 36 – Jog Setpoint

This Item defines the JOG setpoint in engineering units.

Item 42 – Inhibit Configuration

This Item determines the accel/decel profile of the BLDC when it is going into and out of “Inhibit” Mode. There are 4 possible settings:

Mode 0: No Accel/Decel

When going into Inhibit, the BLDC will immediately shut off its output, disregarding any Decel setting, and when coming out of Inhibit, the BLDC will immediately return to its Target Speed, disregarding any Accel setting. This is exactly like the “E-Stop” behavior.

Mode 1: Decel Only, No Accel

When going into Inhibit, the BLDC will Decel to a stop using the setting in Item 24, but when coming out of Inhibit, the BLDC will immediately return to its Target Speed, disregarding any Accel setting.

Mode 2: Accel Only, No Decel

When going into Inhibit, the BLDC will immediately shut off its output, disregarding any Decel setting, but when coming out of Inhibit, the BLDC will Accelerate to its Target Speed, using the Accel setting in Item 23.

Mode 3: Use Both Accel and Decel

When going into Inhibit, the BLDC will Decel to a stop using the setting in Item 24, and when coming out of Inhibit, the BLDC will Accelerate to its Target Speed, using the Accel setting in Item 23.

Item 50 – Alarm 1 Logical “OR” Activation Conditions

This Item, in conjunction with Items 51 & 52, defines which conditions will result in the Alarm 1 output being activated. The function is that of a Logical “OR”ing of the selected Drive Condition Flags. A setting of zero defeats this “OR” function entirely. Please see the sections “Setting and Reading Softswitches” and “Setting Alarm Conditions” for further details.

Item 51 – Alarm 1 Logical Activation Condition Inverters

This Item, in conjunction with Items 50 & 52, defines which conditions will result in the Alarm 1 output being activated. The function allows selected Drive Condition Flags to be “inverted” before being presented to the “inputs” of the “AND” function (see Item 52). Please see the sections “Setting and Reading Softswitches” and “Setting Alarm Conditions” for further details.

Item 52 – Alarm 1 Logical “AND” Activation Conditions

This Item, in conjunction with Items 50 & 51, defines which conditions will result in the Alarm 1 output being activated. The function is that of a Logical “AND”ing of the selected Drive Condition Flags. A setting of zero defeats this “AND” function entirely. Please see the sections “Setting and Reading Softswitches” and “Setting Alarm Conditions” for further details.

Item 53 – Alarm 1 Output Style & Reset Configuration

This setting configures the output mode and reset method for the Alarm 1 output.

Mode 1: Constant & Auto Reset

In this mode, the alarm output will remain active until the alarm condition ceases to exist. The alarm will automatically reset when the conditions return to normal.

Mode 2: Constant & Manual Reset

In this mode, the alarm output will remain active until the alarm is reset manually. See Item 54 for details.

Mode 3: Pulse & Auto Reset

In this mode, the alarm output will pulse on and off until the alarm condition ceases to exist. The pulsed modes are commonly used for audible alarms where a constant output would be considered distracting or awkward. The alarm will automatically reset when the conditions return to normal.

Mode 4: Pulse & Manual Reset

In this mode, the alarm output will pulse on and off until the alarm is reset manually. See Item 54 for reset details. The pulsed modes are commonly used for audible alarms where a constant output would be considered distracting or awkward.

Item 54 – Alarm 1 Reset Configuration

This setting determines which actions will cause an active alarm to be silenced or reset.

Mode 1: No Silencing, Reset On ENTER Button Press

In this mode, an active alarm cannot be silenced. Once the alarm condition ceases to exist, however, the ENTER button may be pressed to cause a manual reset.

Mode 2: Reserved

Mode 3: Reserved

Mode 4: Silencing Enabled, Reset On ENTER Button Press

When the conditions for an active alarm persist, pressing any user-interface button will result in the alarm being silenced or deactivated, but not reset. A second attempt to reset the alarm must be made after the condition ceases to exist to clear the alarm.

Mode 5: Reserved

Mode 6: Reserved

Item 55 – Alarm 1 Annunciator Flash On Alarm

When set to 1, this will cause the “Alm1” LED Annunciator to flash when an alarm 1 condition is active. A setting of zero defeats this function.

Item 56 – Alarm 1 Pulse "ON" Time

This Item defines the number of seconds the output should be enabled during the ‘on’ phase of an active pulsing alarm’s output.

Item 57 – Alarm 1 Pulse "OFF" Time

This Item defines the number of seconds the output should be disabled during the ‘off’ phase of an active pulsing alarm’s output.

Item 58 – Alarm 1 Pulse Count

This setting determines how many pulses are output when the alarm is activated and is configured in the pulse output style. *When 0 is entered, the unit will be set for continuous pulses while the alarm is active.*

Item 59 – Alarm 1 Lower Limit

This setting defines either the lower limit or the lower end of a range for the alarm region. Alarm limits are set in engineering units without regard to decimal point or colon position. In Rate Mode, a limit of 123 could represent a display value of 123, 12.3, 1.23, or 0.123. When in Time Mode, a limit of 123 would represent 1:23 on the display.

Item 60 – Alarm 1 Upper Limit

This setting defines either the upper limit or the upper end of a range for the alarm region. Alarm limits are set in engineering units without regard to decimal point or colon position. In Rate Mode, a limit of 123 could represent a display value of 123, 12.3, 1.23, or 0.123. When in Time Mode, a limit of 123 would represent 1:23 on the display.

Mode 5: Silencing Enabled

Item 70 – Alarm 2 Logical “OR” Activation Conditions

This Item, in conjunction with Items 71 & 72, defines which conditions will result in the Alarm 2 output being activated. The function is that of a Logical “OR”ing of the selected Drive Condition Flags. A setting of zero defeats this “OR” function entirely. Please see the sections “Setting and Reading Softswitches” and “Setting Alarm Conditions” for further details.

Item 71 – Alarm 2 Logical Activation Condition Inverters

This Item, in conjunction with Items 70 & 72, defines which conditions will result in the Alarm 2 output being activated. The function allows selected Drive Condition Flags to be “inverted” before being presented to the “inputs” of the “AND” function (see Item 72). Please see the sections “Setting and Reading Softswitches” and “Setting Alarm Conditions” for further details.

Item 72 – Alarm 2 Logical “AND” Activation Conditions

This Item, in conjunction with Items 70 & 71, defines which conditions will result in the Alarm 2 output being activated. The function is that of a Logical “AND”ing of the selected Drive Condition Flags. A setting of zero defeats this “AND” function entirely. Please see the sections “Setting and Reading Softswitches” and “Setting Alarm Conditions” for further details.

Item 73 – Alarm 2 Output Style & Reset Configuration

This setting configures the output mode and reset method for the Alarm 2 output.

Mode 1: Constant & Auto Reset

In this mode, the alarm output will remain active until the alarm condition ceases to exist. The alarm will automatically reset when the conditions return to normal.

Mode 2: Constant & Manual Reset

In this mode, the alarm output will remain active until the alarm is reset manually. See Item 74 for details.

Mode 3: Pulse & Auto Reset

In this mode, the alarm output will pulse on and off until the alarm condition ceases to exist. The pulsed modes are commonly used for audible alarms where a constant output would be considered distracting or awkward. The alarm will automatically reset when the conditions return to normal.

Mode 4: Pulse & Manual Reset

In this mode, the alarm output will pulse on and off until the alarm is reset manually. See Item 74 for reset details. The pulsed modes are commonly used for audible alarms where a constant output would be considered distracting or awkward.

Item 74 – Alarm 2 Reset Configuration

This setting determines which actions will cause an active alarm to be silenced or reset.

Mode 1: No Silencing, Reset On ENTER Button Press

In this mode, an active alarm cannot be silenced. Once the alarm condition ceases to exist, however, the ENTER button may be pressed to cause a manual reset.

Mode 2: No Silencing, Reset On S2 Input High (Not Wired To Common)

Similar to Mode 1. Once the alarm condition ceases to exist, setting the S2 input to a high (+5V) state or allowing it to float disconnected will cause a manual reset.

Mode 3: No Silencing, Reset On S2 Input Low (Wired To Common)

Similar to Mode 1. Once the alarm condition ceases to exist, setting the S2 input to a low (COM) state or wiring it to common will cause a manual reset.

Mode 4: Silencing Enabled, Reset On ENTER Button Press

When the conditions for an active alarm persist, pressing any user-interface button will result in the alarm being silenced or deactivated, but not reset. A second attempt to reset the alarm must be made after the condition ceases to exist to clear the alarm.

Mode 5: Silencing Enabled, Reset On S2 Input High (Not Wired To Common)

Similar to Mode 4. Setting the S2 input to a high (+5V) state or allowing it to float disconnected will cause the alarm to be silenced or reset depending on the current state of the alarm conditions.

Mode 6: Silencing Enabled, Reset On S2 Input Low (Wired To Common)

Similar to Mode 4. Setting the S2 input to a low (COM) state or wiring it to common will cause the alarm to be silenced or reset depending on the current state of the alarm conditions.

Item 75 – Alarm 2 Annunciator Flash On Alarm

When set to 1, this will cause the “Alm2” LED Annunciator to flash when an alarm 2 condition is active. A setting of zero defeats this function.

Item 76 – Alarm 1 Pulse on Time

This Item defines the number of seconds the output should be enabled during the ‘on’ phase of an active pulsing alarm’s output.

Item 77 – Alarm 1 Pulse off Time

This Item defines the number of seconds the output should be disabled during the ‘off’ phase of an active pulsing alarm’s output.

Item 78 – Alarm 1 Pulse Count

This setting determines how many pulses are output when the alarm is activated and is configured in pulse output style. *When 0 is entered, the unit will be set for continuous pulses while the alarm is active.*

Item 79 – Alarm 1 Lower Limit

This setting defines either the lower limit or the lower end of a range for the alarm region. Alarm limits are set in engineering units without regard to decimal point or colon position. In Rate Mode, a limit of 123 could represent a display value of 123, 12.3, 1.23, or 0.123. When in Time Mode, a limit of 123 would represent 1:23 on the display.

Item 80 – Alarm 1 Upper Limit

This setting defines either the upper limit or the upper end of a range for the alarm region. Alarm limits are set in engineering units without regard to decimal point or colon position. In Rate Mode, a limit of 123 could represent a display value of 123, 12.3, 1.23, or 0.123. When in Time Mode, a limit of 123 would represent 1:23 on the display.

Item 81 – Alarm 2 Output Routing

This setting allows the BLDC to control the “Alarm 1” Output of a selected ModularBus “Slot”, provided of course that there is a ModularBus card that supports this function installed in the selected slot. The valid values for this Item are:

Mode 1: Not Used

Mode 2:Route Alarm 2 Output to ModularBus Slot 100 Alarm 1 Output

In this mode, the BLDC Alarm 2 Output will directly control the Alarm 1 Output of a ModularBus Card installed in Slot 100, if that card supports this feature.

Mode 3:Route Alarm 2 Output to ModularBus Slot 200 Alarm 1 Output

In this mode, the BLDC Alarm 2 Output will directly control the Alarm 1 Output of a ModularBus Card installed in Slot 200, if that card supports this feature.

Mode 4:Route Alarm 2 Output to ModularBus Slot 500 Alarm 1 Output

In this mode, the BLDC Alarm 2 Output will directly control the Alarm 1 Output of a ModularBus Card installed in Slot 500, if that card supports this feature.

“Action” Items (Commands), Items 95 through 99

Rather than being a “setting” or a “switch” type Item, Items 95 through 99 are used to trigger a certain “Action” or “Script” that generally performs some Utility function for the Brushless Control, and/or a ModularBus card installed in the drive. The “value” settings are used as a kind of “key” to make sure these functions are not accidentally “triggered”.

Item 95 – Factory Default Drive Command

When set to a value of 5, and then pressing the ENTER button, the Brushless Micro-Drive (Drive only) will be reset to factory default settings. **THIS ACTION CANNOT BE UNDONE!** This Command can also be achieved by applying power to the unit with both the Enter and Down buttons depressed. *The programming jumper must be in the “On” position for this Command to function.* Any ModularBus card settings are unaffected.

Item 98 – Save (copy) current "Environment" Settings TO User Save Area

When set to a value of 5, and then pressing the ENTER button, the Brushless Control will prompt the user to Save the current "environment" (Settings for the drive and all installed ModularBus cards) TO whichever User Save area ("Settings1" or "Settings2") that is *not* currently being used as the "Working" Settings. **THIS ACTION CANNOT BE UNDONE!** Pressing the "Up" button will Save the settings; pressing any other button will Cancel the operation.

TIP: This feature is often used by OEMs to save their customized settings to a "safe" area, that later can be easily Restored if the need arises.

NOTE: Unless a "Swap" command has been used (see Item 99), the "Working" area is "Settings1". Therefore, this command will normally Save to "Settings2".

Item 99 – Restore/Swap current "Environment" Settings FROM User Save Area

When set to a value of 5 (for "Restore") or 10 (for "Swap"), and then pressing the ENTER button, the Brushless Control will prompt the user to Copy the current "environment" (Settings for the drive and all installed ModularBus cards) FROM whichever User Save area ("Settings1" or "Settings2") that is *not* currently being used as the "Working" Settings. or to "Change" (Swap) between using "Settings1" and "Settings2" as the "Working" Settings area. The "Copy" (Restore) is "destructive", but the "Change" (Swap) is not.

The valid values for this Item are:

Mode 5: Restore Environment from whichever User Save area is not "Current"

Will copy "Settings2" (or "Settings1") settings to the Current ("Working") settings. If the "Working" Settings are coming from "Settings1", then the values in "Settings2" will be used. If the "Working" Settings are coming from "Settings2", then the values in "Settings1" will be used. Either way, the result is that "Settings1" and "Settings2" will end up containing the same values. **THIS ACTION CANNOT BE UNDONE!**

Mode 10: Swap "Working" Settings between "Settings1" and "Settings2"

Non-Destructively "swaps" the "Working" Settings between using "Settings1" and "Settings2". This allows the user to easily play "what-if" type of speculation with one or more Items, without fear of "losing" their current settings. **THE SWAP CAN BE DONE AS MANY TIMES AS DESIRED.**

TIP: The easiest way to find out which area "Settings1 or Settings2" is the "Working" (current) settings, is to enter this mode, and watch the "prompt" to see which area is being offered to "Change to". The current "Working" settings area is the one that is "opposite". For example, if the "prompt" offers to Change to "Settings2", then the Brushless Control (and any ModularBus cards) are currently using "Settings1" as the "Working" area, and vice versa. Then, "Cancel" the "Swap".

Application Example

Conveyor Oven Control with Alarm Output

Description:

BLDC motor controls can set and show the total travel time of a product on a conveyor through an oven-tunnel. An alarm output is available to trigger during various process events.

In this example application, a product is conveyed through an oven tunnel for an adjustable time between 6:30 and 12:15 (MM:SS). It was found through testing that when the motor speed is 1380 RPM a product is moved through the tunnel in 6:40.

If the conveyor unexpectedly stops, the alarm output is programmed to signal the oven control to shutdown the heater. Also, during the alarm event, an LED indicator on the display panel will flash. To reset the alarm output, the enter button is pressed..

Application Diagram:

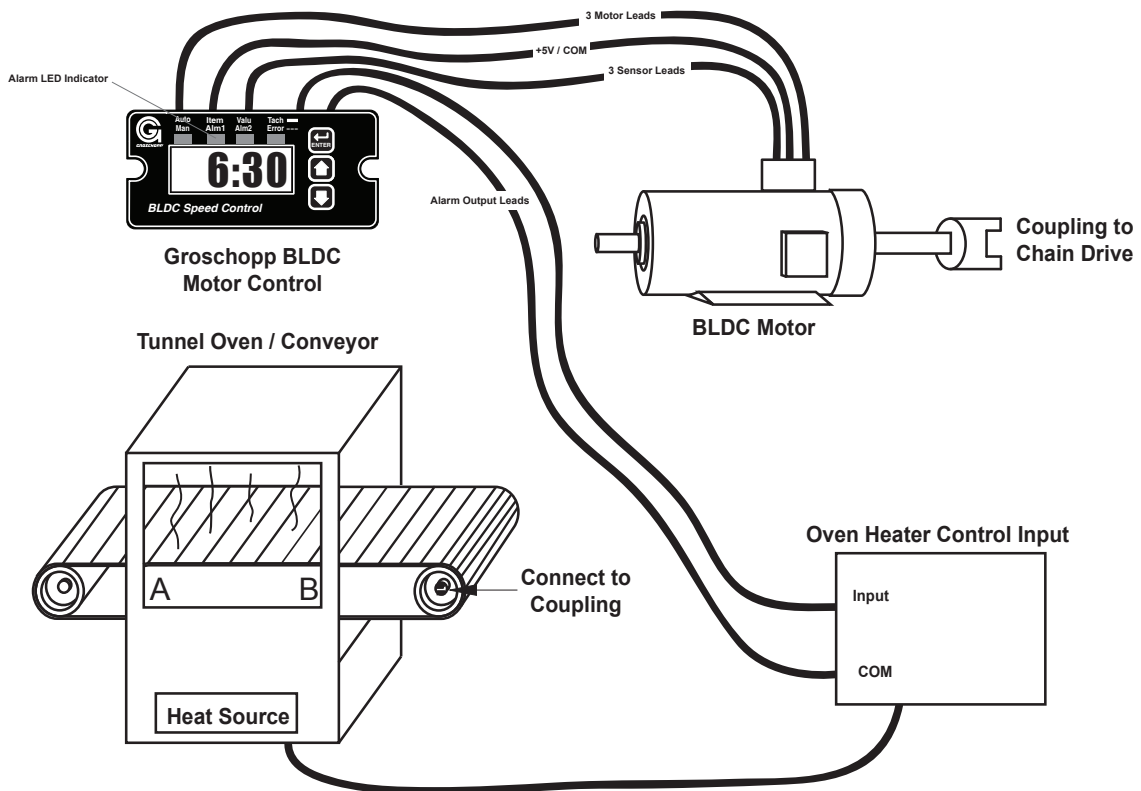

Wiring Diagram:

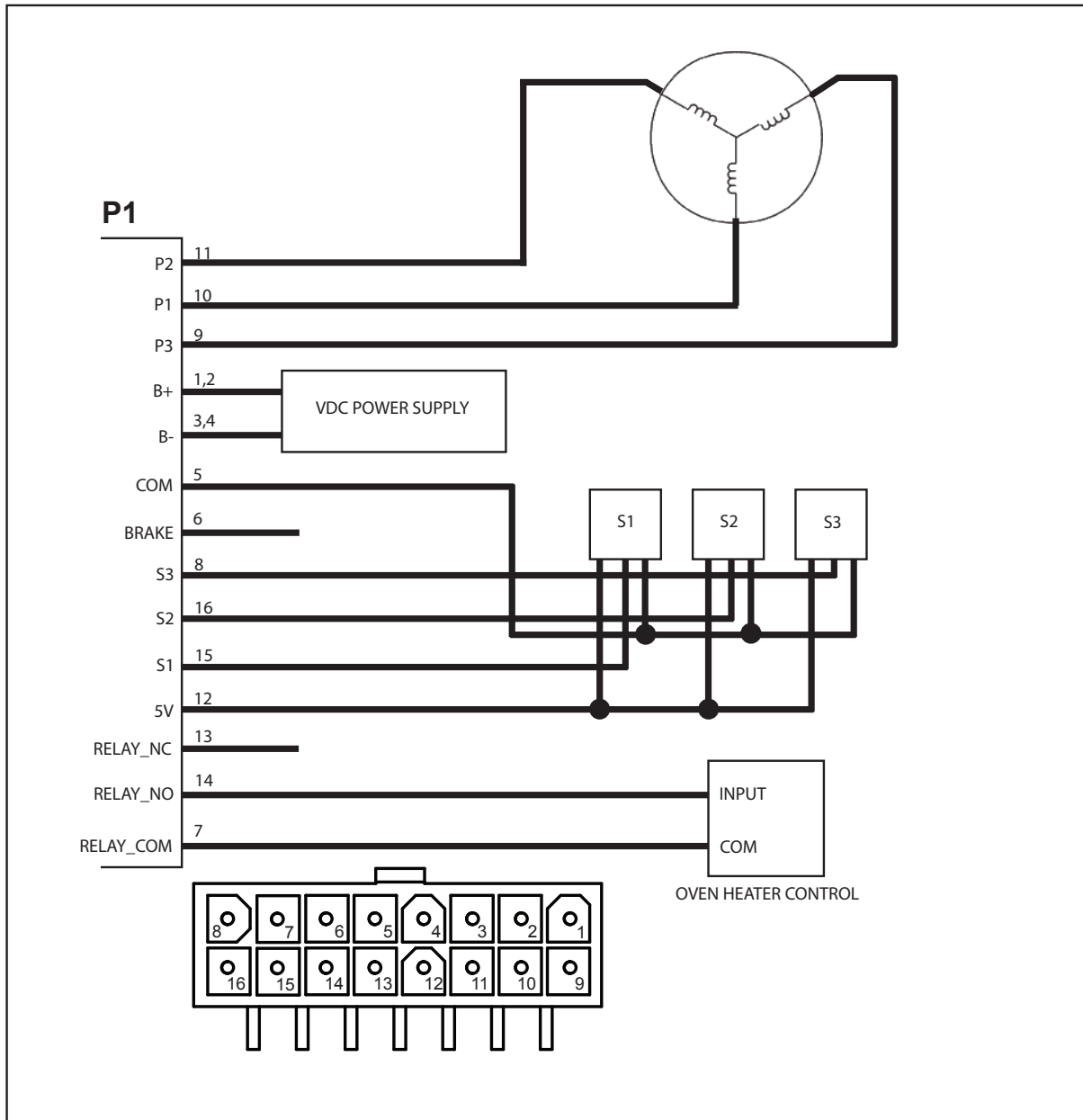

Parameter Configuration:

Parameter	Value	Notes
10	2	Time mode setting. Display will show MM:SS
20	390	Display minimum time is set to 6:30 (MM:SS) For example: (6 minutes x 60 seconds) + 30 seconds = 390 seconds
21	735	Display maximum time is set to 12:15 (MM:SS) For example: (12 x 60 seconds) + 15 seconds = 735 seconds
30	400	Display is set to show 6:40 when motor is at 1380 RPM.
31	1380	For example: (6 minutes x 60 seconds) + 40 seconds = 400 seconds
50	16	Alarm output is set to trigger after loss of speed signal from the motor.
52	1	Alarm output is reset by pressing enter key. (Factory default setting)
55	1	Display alarm LED is set to flash when alarm is triggered.

Troubleshooting

Problem	Possible Cause	Solution
Display is blank	Power not applied	Using a volt meter, verify that the input supply voltage is measured between the P1-1 & P1-4 terminal block positions.
	Defective unit	Contact technical support for additional help and instructions.
Display is dim	Display intensity parameter is too low	Editing and increasing the display intensity parameter should cause the display digits to become brighter.
Displays Speed Incorrectly	Pulses per revolution is wrong	Edit the PPR parameter to match half of the number of motor poles.
Motor is Running Erractic	Senors/Phases attached incorrectly	Review the appropriate hook-up procedure for motors.

Specifications

Electrical

Input Voltage	(Jumper selectable) 10-14VDC or 18-53VDC
Load Current (continuous).....	8 Amps
Overload Current.....	150% for 30 seconds
Current Limit.....	Adjustable 0 - 150%
Motor Hall Spacing (Electrical)	(jumper selectable) 60° or 120°
Sensor Power Supply.....	5V @ 50mA
Display Range	0 – 9999
Units of Operation (“Engineering Units”)	User Programmable, any Units
Speed Regulation.....	± 1/2 RPM

Mechanical

Display Type	LED, Red, 4 Digit, ½” Height
Housing Type	NEMA 4X
Connector Style (pluggable connector)	16-position, Dual Row (SAMTEC - IPBT-108-HI-T-D-RA) Mated with SAMTEC: IPBD-08-D **
Faceplate Material.....	Polycarbonate with Polycarbonate Overlay
Housing Material	Aluminum
Length (Required Panel Depth).....	4.625” (117.48mm)
Faceplate Width	4.539” (115.29mm)
Weight DB2110D-2	0.87 lbs (13.92 oz.) (394.625g)

** Use Samtec Model CC69L-1620-01-T-HP Connector Pins (16-20 AWG)

Environmental

Operating Temperature Range.....	-10C to 45C (14F to 113F)
Operating Humidity Range (max.).....	95%, non-condensing

Dimension Chart

<i>Model</i>	<i>Width</i>	<i>Height</i>	<i>Depth</i>
English (inches)			
Housing	3.62	1.66	4.625
Lens	4.539	2.289	0.375
Metric (millimeters)			
Housing	91.94	42.16	117.27
Lens	115.28	58.14	9.53

