

frame size 23

PARALLEL SHAFT

These reducers are the largest parallel shaft frame size Groschopp offers. They maintain all of the input speeds, ratios, continuous torque and yield torque figures as the middle reducer frame size, complete with their 1800 RPM input speeds.

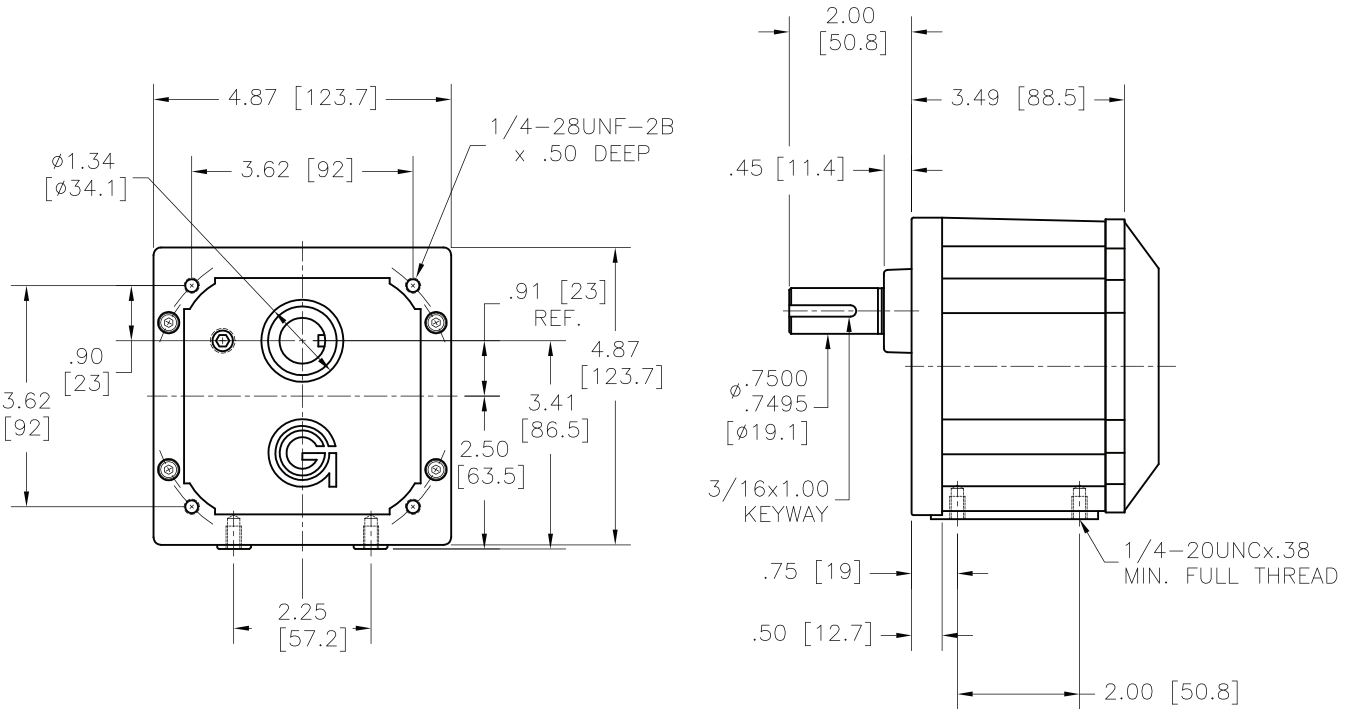

Reducer	Input Speed* (RPM)	Ratio	Continuous Torque (lb-in)	Yield Torque (lb-in)
PS2305	1800	5:1	25	150
PS2310	1800	10:1	50	300
PS2315	1800	15:1	75	450
PS2320	1800	20:1	100	600
PS2330	1800	30:1	140	800
PS2340	1800	40:1	150	1200
PS2350	1800	50:1	175	1200
PS2360	1800	60:1	225	1200
PS2390	1800	90:1	225	1200
PS23120	1800	120:1	300	1200
PS23180	1800	180:1	300	2200
PS23240	1800	240:1	325	2200
PS23300	1800	300:1	350	2200

*Input speeds based on Groschopp's life tests, other speeds available

All dimensions are nominal
Measurements in inches [mm]

Groschopp's standard parallel shaft gearboxes use oil, but a variety of grease options are available upon request.