

frame size

# 40

# RIGHT ANGLE

Reaching ratios as high as 100:1 (starting from 5:1), Groschopp's right angle, size 40 frame, line of twelve reducers reach continuous torque ranging from 77 to 182 lb-in. In conjunction with these numbers, yield torque ranges from 708 to 2747 lb-in.

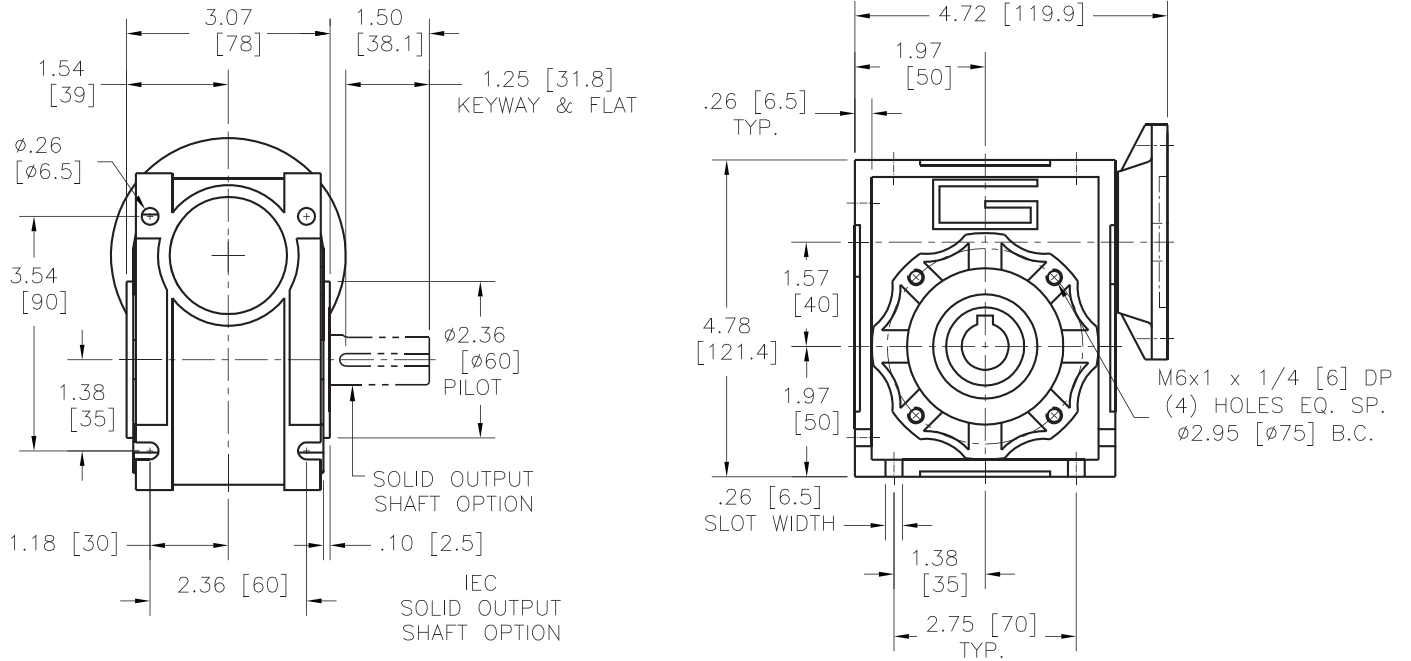

Reducer	Input Speed* (RPM)	Ratio	Continuous Torque (lb-in)	Yield Torque (lb-in)
RA4005	1800	5:1	148	2743
RA4007	1800	7.5:1	141	2743
RA4010	1800	10:1	130	2743
RA4015	1800	15:1	114	2743
RA4020	1800	20:1	138	2743
RA4025	1800	25:1	182	1947
RA4030	1800	30:1	90	2747
RA4040	1800	40:1	115	1947
RA4050	1800	50:1	92	2743
RA4060	1800	60:1	77	1460
RA4080	1800	80:1	103	973
RA40100	1800	100:1	182	708

\*Input speeds based on Groschopp's life tests, other speeds available

All dimensions are nominal  
Measurements in inches [mm]

Shaft kits, torque arms, output flanges, input flanges and dust covers are available upon request for Groschopp's Right Angle gearboxes.