

AC INDUCTION MOTOR CONTROL

GROSCHOPP MODEL NUMBER: DA1230K-0

750-10-0001

This control allows equipment to operate with Ground Fault Circuit Interruption circuit breakers or outlets. It saves time, is easy to install, and is simple to operate. It does not require programming and is able to be up and running in less than 10 minutes. This control provides overload protection, allowing motors to last longer by preventing motor burnout and eliminating nuisance tripping. It also saves energy as it only uses the power required for the application. Replacing constant speed with variable speed will significantly reduce energy costs as well.

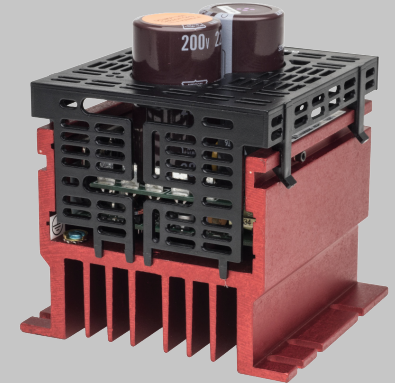
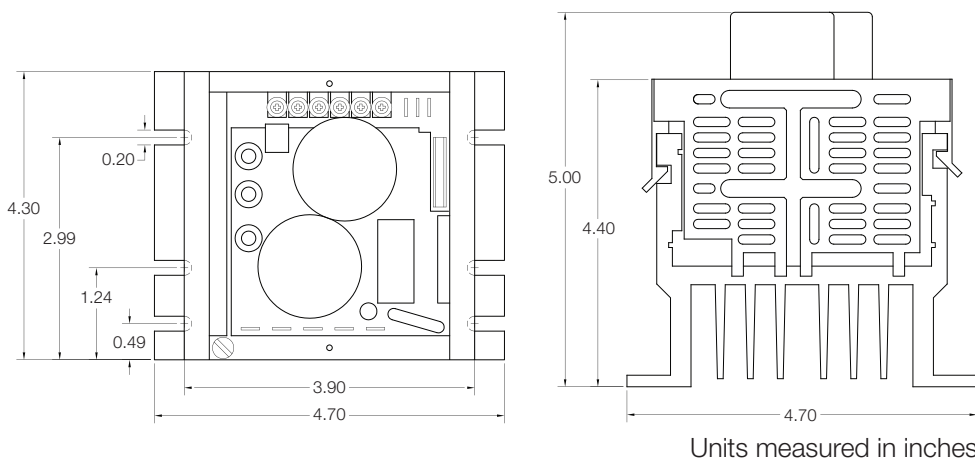

AC LINE INPUT - 115V

Voltage (V), 50/60 Hz – 115

Phase (Ø) – 1

Max Current (A) – 14.0

Fuse/Circuit Breaker Rating (A) – 20

AC LINE INPUT - 208/230V

Voltage (V), 50/60 Hz – 208/230

Phase (Ø) – 1

Max Current (A) – 10.0

Fuse/Circuit Breaker Rating (A) – 15

DRIVE OUTPUT

Voltage Range (V) – 0-230

Phase (Ø) – 3

Max Cont. Load Current (RMS A/Ø) – 4.0

Max Power (hp) – 1

Max Power (kW) – 0.75

Diagnostic LEDs

Slip compensation with static auto-tune and boost

Motor overload I²T with RMS current limit

Undervoltage/overvoltage protection

Microcontroller self monitoring and auto-reboot

Features: acceleration, deceleration, brake, inhibit

Jumper selection of drive output frequency

Electric inrush current limit

Industry standard mounting

Finger safe cover

MOV input transient suppression

Short circuit protection

Simple to operate

Speed regulation: $\pm 2.5\%$ base speed

Speed range: 60:1

Length: 4.70 in.

Width: 4.30 in.

Height: 5.0 in.

Enclosure Type: Chassis